

# Oak RH

## Humidity and Temperature Sensor

# Datasheet



### Revision history

Date	Doc. Rev.	Changes
21-Jun-2011	Rev. 1.7	Disclaimer Update
21-Mar-2011	Rev. 1.6	Changed units of temperature resolution and accuracy
22-Feb-2011	Rev. 1.5	Added note about accuracy of temperature measurement
17-Jan-2011	Rev. 1.4	Modified Sample Rate Range
29-Oct-2010	Rev. 1.3	Added Operating Temperature Range
30-Sep-2010	Rev. 1.2	Added USB Vendor ID and Product ID
29-Feb-2008	Rev. 1.1	Minor Edits (section 1.1)
23-Mar-2007	Rev. 1.0	Initial Release



# Contents

<b>1. Introduction</b> .....	<b>3</b>
1.1 Reference Documents .....	3
<b>2. Hardware Specifications</b> .....	<b>4</b>
2.1 Sensor: Sensirion SHT15 .....	4
2.2 Measurement Range .....	4
2.3 Supported Sensor Features .....	4
2.4 USB Interface .....	4
2.5 Operating Temperature Range .....	4
<b>3. Software Specifications</b> .....	<b>5</b>
3.1 INTERRUPT IN Report Contents (Real time data) .....	5
3.2 FEATURE Report Commands .....	5
<b>4. Technical Specifications</b> .....	<b>8</b>
4.1 Electrical Specifications .....	8
4.2 Mechanical Dimensions .....	8
4.3 RoHS Compliance .....	8



# 1. Introduction

---

The Oak-RH is a USB attached sensor for relative humidity and temperature. The application of industrial CMOS processes with patented micro-machining for the sensor ensures highest reliability and excellent long term stability

The Oak-RH can be integrated in a custom application very easily. The operating power as well as real time sensor data and uncritical sensor configuration data are all transferred through a simple USB cable. The very low power consumption, including automatic entering into sleep mode, allows using the device not only in fixed installations, but also in mobile applications.

## 1.1 Reference Documents

Sensor Datasheet:

[http://files.toradex.com/Oak/Datasheets/Components/Oak\\_RH/Datasheet-humidity-sensor-SHT1x.pdf](http://files.toradex.com/Oak/Datasheets/Components/Oak_RH/Datasheet-humidity-sensor-SHT1x.pdf)

Programming Guide for the Oak Sensor Family:

[http://files.toradex.com/Oak/Oak\\_ProgrammingGuide.pdf](http://files.toradex.com/Oak/Oak_ProgrammingGuide.pdf)

Oak Programming Tutorial for Windows:

[http://wiki.toradex.com/index.php/Oak\\_Programming\\_Tutorial\\_for\\_Windows](http://wiki.toradex.com/index.php/Oak_Programming_Tutorial_for_Windows)



## 2. Hardware Specifications

---

### 2.1 Sensor: Sensirion SHT15

The SHT15 is a single chip relative humidity and temperature multi sensor module comprising a calibrated digital output. Application of industrial CMOS processes with patented micro-machining ensures highest reliability and excellent long term stability. The device includes a capacitive polymer sensing element for relative humidity and a bandgap temperature sensor. The on-chip analog to digital converter results in superior signal quality, a fast response time and insensitivity to external disturbances (EMC) at a very competitive price.

Each SHT15 is individually calibrated in a precision humidity chamber.

### 2.2 Measurement Range

Humidity: 0-100 %RH  
Resolution: 0.05 %RH

Temperature: -10 to 85 °C (limited by operating temperature range, see paragraph 2.5)  
Resolution: 0.01 °C  
Accuracy:  $\pm 2$  °C

Note: Toradex does not recommend using the sensor for precise temperature measurements, as the accuracy is significantly reduced due to self-heating by the microcontroller.

For more details, please refer to the sensor datasheet (link in chapter 1.1)

### 2.3 Supported Sensor Features

Read humidity

Read temperature

Heater on/off

12bit / 8bit resolution for humidity (configurable)

14bit / 12bit resolution for temperature (configurable)

Sample rate adjustable

### 2.4 USB Interface

Interface: USB 2.0 Full Speed (12Mbit/s)

Connector: Standard USB Mini-B

Device Class: HID

Vendor ID: 0x1B67

Product ID: 0x0001

Sampling Rate: 77ms to 65s, user adjustable

Report Rate: 1ms to 65s, user adjustable

### 2.5 Operating Temperature Range

Minimum Operating Temperature: -10 °C

Maximum Operating Temperature: +85 °C



### 3. Software Specifications

All Oak Sensors are implemented as HID devices. Thus driver support is built into all major operating systems.

Captured sensor Data is transmitted through an INTERRUPT IN reports. Therefore real time processing can be guaranteed. This data can be received by the host using regular file read operations. Chapter 0 describes the contents of this report.

On an independent communication channel, sensor configuration is done using FEATURE reports that are 32 Bytes in length. Special operating system calls exist to transmit / receive feature reports. Chapter 3.2 shows the structure of a feature report for each supported command.

Please refer also to the document "Programming Guide to the Oak Sensor Family" for more details.

#### 3.1 INTERRUPT IN Report Contents (Real time data)

16 Bit	Frame Number	$10^{-3}$	s
16 Bit	Relative Humidity	$10^{-4}$	-
16 Bit	Temperature	$10^{-2}$	K

#### 3.2 FEATURE Report Commands

##### 3.2.1 Report Mode

Byte#	0	1	2	3	4	5
Content	GnS	Tgt	0x01	0x00	0x00	RPTMODE

GnS: 0 = Set  
1 = Get

Tgt 0 = RAM  
1 = Flash

RPTMODE: 0 = After Sampling (Factory Default)  
1 = After Change  
2 = Fixed Rate

##### 3.2.2 LED Mode

Byte#	0	1	2	3	4	5
Content	GnS	Tgt	0x01	0x01	0x00	LEDMODE

GnS: 0 = Set  
1 = Get

Tgt 0 = RAM  
1 = Flash

LEDMODE: 0 = Off (Factory Default)  
1 = On  
2 = Blink Slowly  
3 = Blink Fast  
4 = Blink 4 pulses



## Oak RH Datasheet

### 3.2.3 Report Rate

Number of milliseconds between two IN reports. This parameter will only be regarded if Report Mode = 2 (fixed rate)

Byte#	0	1	2	3	4	5	6
Content	GnS	Tgt	0x02	0x00	0x00	RptRate LSB	RptRate MSB

GnS: 0 = Set  
1 = Get

Tgt 0 = RAM  
1 = Flash

RptRate: Report Rate [ms]

### 3.2.4 Sample Rate

This is the actual sample rate the sensor is working on. If Report Mode = 0 (After Sampling) this is also the rate at which the device reports values to the host PC.

Byte#	0	1	2	3	4	5	6
Content	GnS	Tgt	0x02	0x01	0x00	SampRate LSB	SampRate MSB

GnS: 0 = Set  
1 = Get

Tgt 0 = RAM  
1 = Flash

SampRate: Sample Rate [ms]

### 3.2.5 User Device Name

Byte#	0	1	2	3	4	5-25
Content	GnS	Tgt	0x15	0x00	0x00	UsrDevName

GnS: 0 = Set  
1 = Get

Tgt 0 = RAM  
1 = Flash

UsrDevName: User defined name for the whole device  
Null-terminated string, max. 20+1 characters

### 3.2.6 User Channel Name

Byte#	0	1	2	3	4	5-25
Content	GnS	Tgt	0x15	ChP1	0x00	UsrChName

GnS: 0 = Set  
1 = Get

Tgt 0 = RAM  
1 = Flash

ChP1 1 = Channel 0 (Frame Number)  
2 = Channel 1 (Humidity)  
3 = Channel 2 (Temperature)

UsrChName: User defined name for the channel  
Null-terminated string, max. 20+1 characters



## Oak RH Datasheet

### 3.2.7 Sensor Status

Byte#	0	1	2	3	4	5
Content	GnS	Tgt	0x01	0x02	0x00	SNSSTATUS

GnS:           0 = Set  
               1 = Get

Tgt            0 = RAM  
               1 = Flash

SNSSTATUS:   0 = Heater off, 12bit RH / 14bit temperature resolution  
               1 = Heater off, 8bit RH / 12bit temperature resolution  
               4 = Heater on, 12bit RH / 14bit temperature resolution  
               5 = Heater on, 8bit RH / 12bit temperature resolution



## 4. Technical Specifications

### 4.1 Electrical Specifications

Symbol	Parameter	Conditions	Min	Typ	Max	Unit
$I_a^{1)}$	Operating current				20	mA
$I_{Stby}$	Standby current	No USB activity			500	$\mu$ A

<sup>1)</sup> The maximum operating current is mainly influenced by the on board LED.

### 4.2 Mechanical Dimensions

The PCB is designed to be mounted using two standard M2 screws. There are no components on the back side of the pcb.

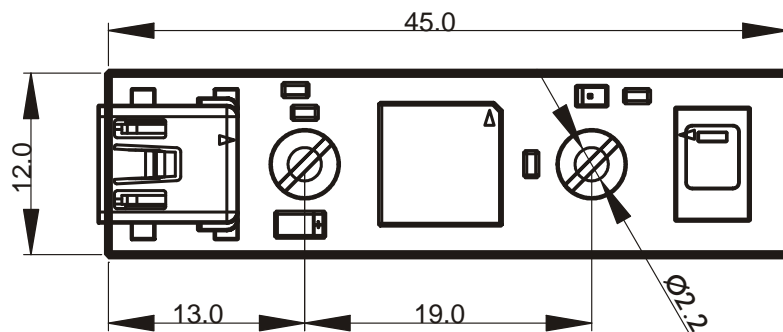

Figure 1: Mechanical dimensions of the Oak RH sensor

### 4.3 RoHS Compliance

Unless otherwise stated, all Toradex products comply with the European Union's Directive 2002/95/EC: "Restrictions of Hazardous Substances".





**Disclaimer:**

Copyright © Toradex AG. All rights reserved. All data is for information purposes only and not guaranteed for legal purposes. Information has been carefully checked and is believed to be accurate; however, no responsibility is assumed for inaccuracies.

Brand and product names are trademarks or registered trademarks of their respective owners. Specifications are subject to change without notice.