

Oak In

8 Channel Isolated Digital Inputs, 36V Tolerant

Datasheet

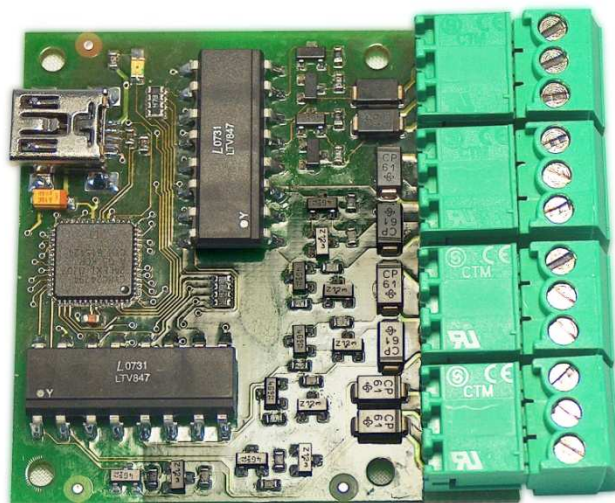

Revision history

Date	Doc. Rev.	Changes
21-Jun-2011	Rev. 1.4	Disclaimer Update
17-Jan-2011	Rev. 1.3	Minor Edits
29-Oct-2010	Rev. 1.2	Added Operating Temperature Range
30-Sep-2010	Rev. 1.1	Added USB Vendor ID and Product ID
28-Feb-2008	Rev. 1.0	Initial Release
07-Nov-2007	Rev. 0.9	Preliminary Release



Contents

1. Introduction	3
1.1 Reference Documents	3
2. Hardware Specifications	4
2.1 Input Specifications	4
2.2 Equivalent Input Circuit	4
2.3 Pin Assignment	5
2.4 Supported Input Features	5
2.5 USB Interface	5
2.6 Operating Temperature Range	5
3. Software Specifications	6
3.1 INTERRUPT IN Report Contents (Real time data)	6
3.2 FEATURE Report Commands	6
4. Technical Specifications	8
4.1 Current Consumption	8
4.2 Mechanical Dimensions	8
4.3 RoHS Compliance	8



1. Introduction

The Oak In is a USB attached digital input device with 8 input channels. All channels are electrically isolated from each other as well as from the host computer. The Oak In supports input voltages of up to 36 Volts and can be even used for 3.3 Volt logic. All inputs are ESD protected and feature disconnectable interfaces. The mating connectors have screw terminals for a quick attachment of bare wires.

The Oak In can be integrated in a custom application very easily. The operating power as well as real time digital input data and uncritical device configuration data are all transferred through a simple USB cable. The very low power consumption, including automatic entering into sleep mode, allows using the device not only in fixed installation, but also in mobile applications.

1.1 Reference Documents

Programming Guide to the Oak Sensor Family



2. Hardware Specifications

2.1 Input Specifications

The Oak In board has a built in current limiter for each channel. With this limiter, the digital inputs support a wide input voltage range.

Description	Min.	Typ.	Max.	Notes
DC Input Voltage			36	Absolute Maximum Ratings $V_{in} = 24V$
Input High Level	2.3V		-	
Input Low Level	-		1.5V	
Input Current		1.3mA	2.2mA	

The input low level threshold can be increased using an external series resistor. The following diagram plots the logic levels versus the external series resistor value.

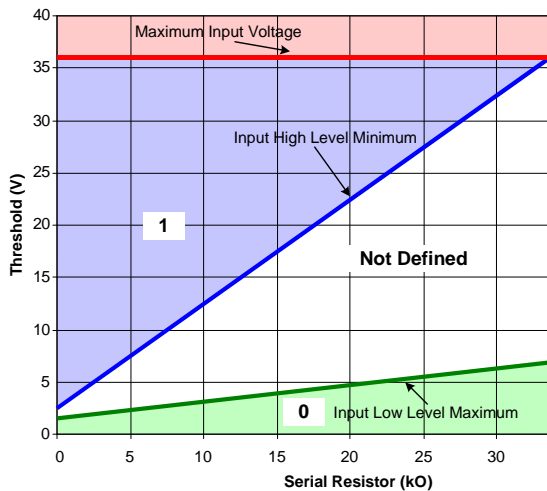

Figure 1: Input Level Threshold with Serial Resistor

2.2 Equivalent Input Circuit

The 8 input channels are grouped into 4 channel pairs. Each pair has a common negative input terminal. Therefore, the two channels of a pair are electrically coupled, but the isolation between two pairs is guaranteed.

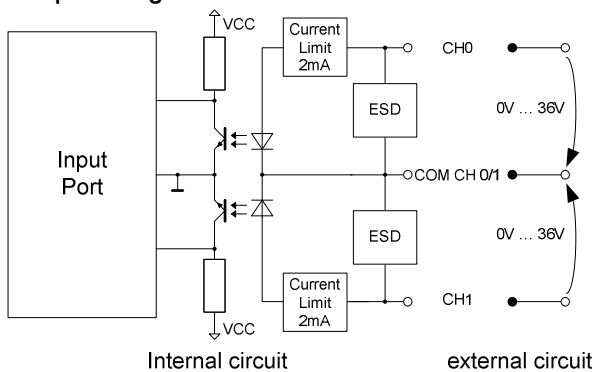

Figure 2: Equivalent input circuit for each channel pair



2.3 Pin Assignment

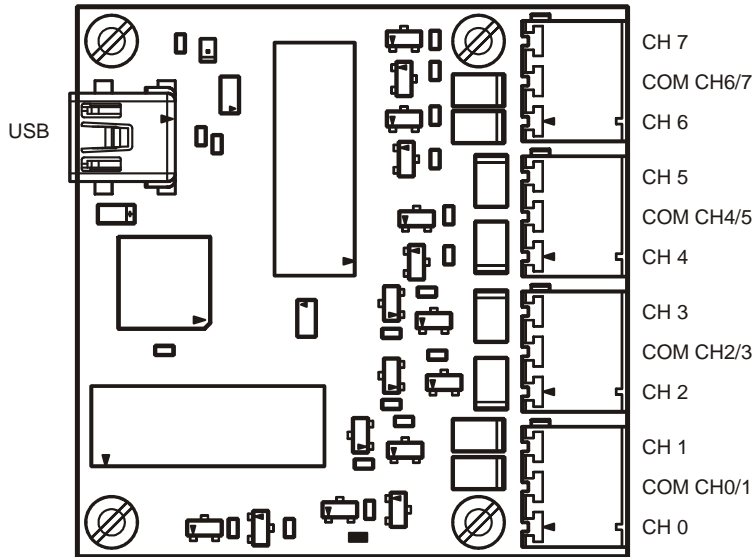

Figure 3: Pin assignment of the Oak In device

2.4 Supported Input Features

Read digital inputs

Sample rate adjustable

2.5 USB Interface

Interface: USB 2.0 Full Speed (12Mbits/s)

Connector: Standard USB Mini-B

Device Class: HID

Vendor ID: 0x1B67

Product ID: 0x000F

Update Rate: 1ms to 65s, user adjustable

Report Rate: 1ms to 65s, user adjustable

2.6 Operating Temperature Range

Minimum Operating Temperature: -10°C

Maximum Operating Temperature: +85°C



3. Software Specifications

All Oak Devices are implemented as HID devices. Thus driver support is built into all major operating systems.

The converted digital input data is transmitted through an INTERRUPT IN report. Therefore real time processing can be guaranteed. The data can be received by the host using regular file read operation. Chapter 3.1 describes the contents of this report.

On an independent communication channel, device configuration is done using FEATURE reports that are 32 Bytes in length. Special operating system calls exist to transmit / receive feature reports. Chapter 3.2 shows the structure of a feature report for each supported command.

Please refer also to the document "Programming Guide to the Oak Sensor Family" for more details.

3.1 INTERRUPT IN Report Contents (Real time data)

The INTERRUPT IN report contains the following items:

16 Bit Frame Number 10^{-3} s
 8 Bit Digital Inputs

3.2 FEATURE Report Commands

3.2.1 Report Mode

Byte#	0	1	2	3	4	5
Content	GnS	Tgt	0x01	0x00	0x00	RPTMODE

GnS: 0 = Set
 1 = Get

Tgt 0 = RAM
 1 = Flash

RPTMODE: 0 = After Sampling (Factory Default)
 1 = After Change
 2 = Fixed Rate

3.2.2 LED Mode

Byte#	0	1	2	3	4	5
Content	GnS	Tgt	0x01	0x01	0x00	LEDMODE

GnS: 0 = Set
 1 = Get

Tgt 0 = RAM
 1 = Flash

LEDMODE: 0 = Off (Factory Default)
 1 = On
 2 = Blink Slowly
 3 = Blink Fast
 4 = Blink 4 pulses



Oak In Datasheet

3.2.3 Report Rate

Number of milliseconds between two IN reports. This parameter will only be regarded if Report Mode = 2 (fixed rate)

Byte#	0	1	2	3	4	5	6
Content	GnS	Tgt	0x02	0x00	0x00	RptRate LSB	RptRate MSB

GnS: 0 = Set
1 = Get

Tgt 0 = RAM
1 = Flash

RptRate: Report Rate [ms]

3.2.4 Sample Rate

This is the actual sample rate the device is working on. If Report Mode = 0 (After Sampling) this is also the rate at which the device reports values to the host PC.

Byte#	0	1	2	3	4	5	6
Content	GnS	Tgt	0x02	0x01	0x00	SampRate LSB	SampRate MSB

GnS: 0 = Set
1 = Get

Tgt 0 = RAM
1 = Flash

SampRate: Sample Rate [ms]

3.2.5 User Device Name

Byte#	0	1	2	3	4	5-25
Content	GnS	Tgt	0x15	0x00	0x00	UsrDevName

GnS: 0 = Set
1 = Get

Tgt 0 = RAM
1 = Flash

UsrDevName: User defined name for the whole device
Null-terminated string, max. 20+1 characters

3.2.6 User Channel Name

Byte#	0	1	2	3	4	5-25
Content	GnS	Tgt	0x15	ChP1	0x00	UsrChName

GnS: 0 = Set
1 = Get

Tgt 0 = RAM
1 = Flash

ChP1 1 = Channel 0 (Frame Number)
2 = Channel 1 (Digital Inputs)

UsrChName: User defined name for the channel
Null-terminated string, max. 20+1 characters



4. Technical Specifications

4.1 Current Consumption

Symbol	Parameter	Conditions	Min	Typ	Max	Unit
I_q	Operating current				30	mA
I_{Stby}	Standby current	No USB activity			500	μ A

4.2 Mechanical Dimensions

The PCB is designed to be mounted using four standard M2 screws. There are no components on the back side of the PCB, but there are through-hole components on top.

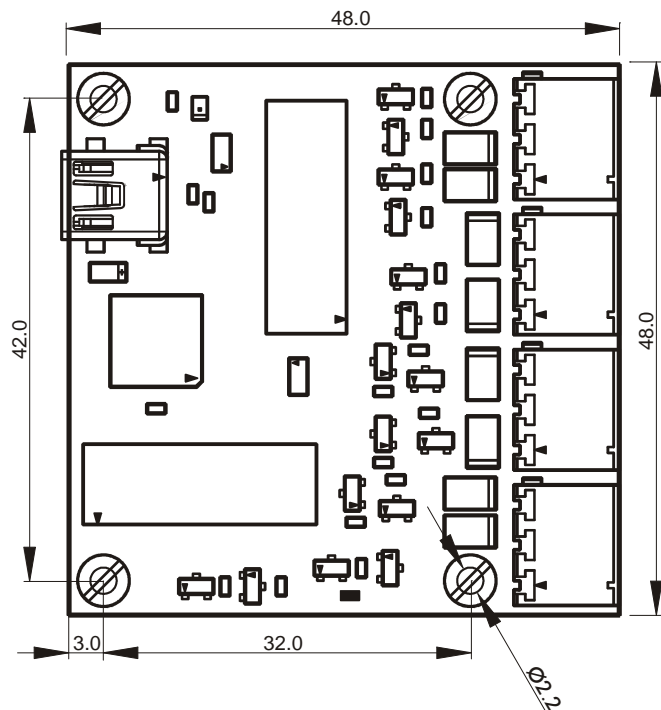

Figure 4: Mechanical dimensions of the Oak In device

4.3 RoHS Compliance

Unless otherwise stated, all Toradex products comply with the European Union's Directive 2002/95/EC: "Restrictions of Hazardous Substances".



Disclaimer:

Copyright © Toradex AG. All rights reserved. All data is for information purposes only and not guaranteed for legal purposes. Information has been carefully checked and is believed to be accurate; however, no responsibility is assumed for inaccuracies.

Brand and product names are trademarks or registered trademarks of their respective owners. Specifications are subject to change without notice.