

Oak IO

24 Digital Inputs / Outputs

3.3V or 5V Logic Level

Datasheet

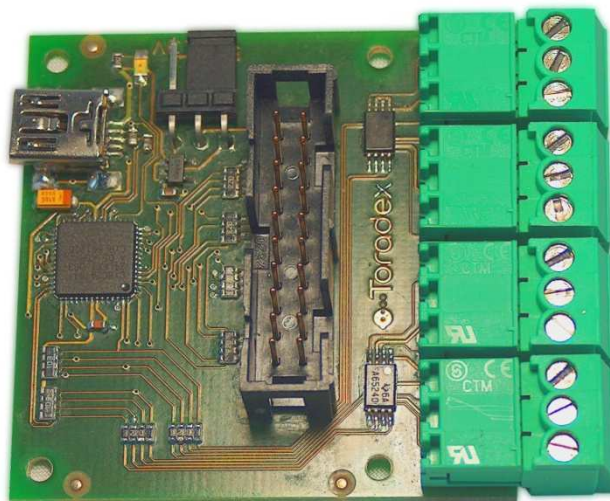

Revision history

| Date | Doc. Rev. | Changes |
|-------------|-----------|--|
| 21-Jun-2011 | Rev. 1.5 | Disclaimer Update |
| 17-Jan-2011 | Rev. 1.4 | Minor Edits |
| 29-Oct-2010 | Rev. 1.3 | Added Operating Temperature Range |
| 30-Sep-2010 | Rev. 1.2 | Added USB Vendor ID and Product ID |
| 28-May-2009 | Rev. 1.1 | Add description of Output setting via Feature Report |
| 28-Feb-2008 | Rev. 1.0 | Initial Release |
| 07-Nov-2007 | Rev. 0.9 | Preliminary Release |



Contents

| | |
|--|-----------|
| 1. Introduction | 3 |
| 1.1 Reference Documents | 3 |
| 2. Hardware Specifications | 4 |
| 2.1 I/O Ports | 4 |
| 2.2 I/O Specifications | 4 |
| 2.3 Equivalent Input / Output Circuit | 5 |
| 2.4 Switch Input | 5 |
| 2.5 Pin Assignment | 6 |
| 2.6 Jumper Setting | 7 |
| 2.7 Supported I/O Features | 7 |
| 2.8 USB Interface | 7 |
| 2.9 Operating Temperature Range | 7 |
| 3. Software Specifications | 8 |
| 3.1 INTERRUPT OUT Report Contents (Real time data) | 8 |
| 3.2 INTERRUPT IN Report Contents (Real time data) | 9 |
| 3.3 FEATURE Report Commands | 9 |
| 4. Technical Specifications | 13 |
| 4.1 Current Consumption | 13 |
| 4.2 Mechanical Dimensions | 13 |
| 4.3 RoHS Compliance | 13 |



1. Introduction

The Oak IO is a USB attached digital input / output board. Each of the 24 I/Os can be configured individually to act as CMOS input, CMOS output or open drain I/O. The logic level of all I/Os can be set to 3.3V or 5V by a single jumper.

8 of the 24 I/O lines are ESD protected and have disconnectable interfaces. The mating connectors feature screw terminals to allow a quick attachment of bare wires. These I/O lines are provided with pull up resistors to allow direct sensing of switches without external circuitry.

For the other 16 I/O lines, a pin header with a 2.54mm pitch is provided for a simple connection of the inputs and outputs.

The output lines can be set with a maximum USB latency of 1ms. The report rate for reading the I/O pins is user adjustable from 1ms to 65s. The minimum USB latency for reading the inputs is therefore 1ms.

The Oak IO can be integrated in a custom application very easily. The operating power as well as real time input/output data and uncritical device configuration data are all transferred through a simple USB cable. The very low power consumption, including automatic entering into sleep mode, allows using the device not only in fixed installation, but also in mobile applications.

1.1 Reference Documents

Cypress CY8C24794 Datasheet:

http://download.cypress.com.edgesuite.net/design_resources/datasheets/contents/cy8c24794_8.pdf

Programming Guide to the Oak Sensor Family



2. Hardware Specifications

2.1 I/O Ports

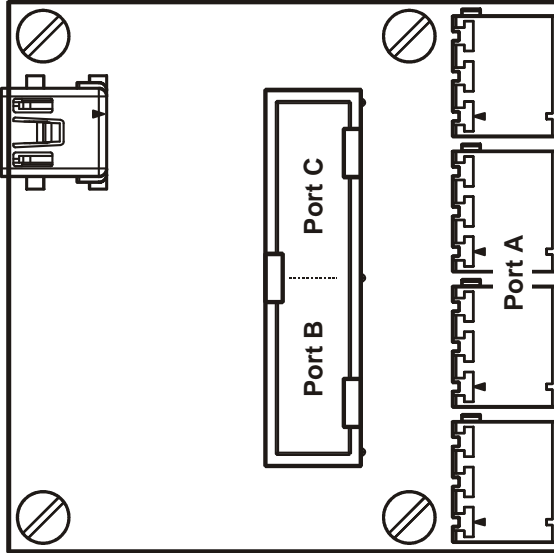

Figure 1: Different ports of the Oak IO device

2.2 I/O Specifications

The Oak IO board can be used in the 3.3V or in the 5V logic level mode. The mode can be changed globally by displacing a jumper.

Each of the 24 I/Os can be configured individually to act as CMOS input, CMOS output or open drain I/O. The I/O mode is different for regular operation and standby. For being USB compliant, the output pins of the board have to be configured as high impedance for standby mode. With feature reports, the Oak IO can be configured to not change the state of the output pins in the standby mode. In this configuration, the Oak IO is not USB compliant. The power of the pull-up resistors of the I/O port A are always switched off in standby mode.

The Oak IO board uses the GPIOs of the Cypress CY8C24794 microcontroller for the digital inputs and outputs. The specification for the ports can be found in the documentation of this controller. The following specifications are a short overview of the most important figures.

2.2.1 Absolute Maximum Ratings at I/O Pins

| Description | 3.3V mode | | 5V mode | | Notes |
|------------------|-----------|------|---------|--------------------|-------------------|
| | Min. | Max. | Min. | Max. | |
| DC Input Voltage | -0.5V | 3.8V | -0.5V | $V_{USB}^* + 0.5V$ | |
| Max. Current | -25mA | 50mA | -25mA | 50mA | Only one pin used |

* V_{USB} is typically 5V, for more information, see USB specification.



2.2.2 DC I/O Pin Specifications

| Description | 3.3V mode | | 5V mode | | Notes |
|-------------------|-----------|------|--------------------|------|-----------------|
| | Min. | Max. | Min. | Max. | |
| Output High Level | 2.0V | - | $V_{USB}^* - 1.3V$ | - | $I_{OH} = 10mA$ |
| Output Low Level | - | 1.3V | - | 1.3V | $I_{OL} = 25mA$ |
| Output High Level | 2.3V | - | $V_{USB}^* - 1.0V$ | - | $I_{OH} = 1mA$ |
| Output Low Level | - | 0.75 | - | 0.75 | $I_{OL} = 1mA$ |
| Input High Level | 2.1V | - | 2.1V | - | |
| Input Low Level | - | 0.8V | - | 0.8V | |

* V_{USB} is normally 5V, for more information, see USB specification.

2.3 Equivalent Input / Output Circuit

The equivalent input circuit of the I/O port A is different from the port B and C, because of the ESD protection and the internal pull up resistor.

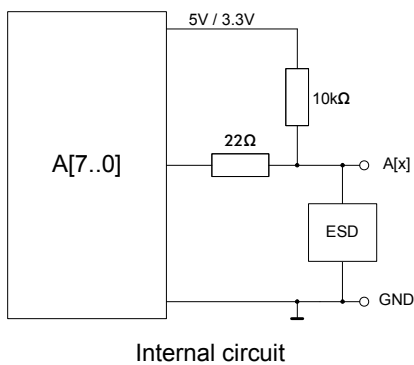

Figure 2: I/O circuit for port A

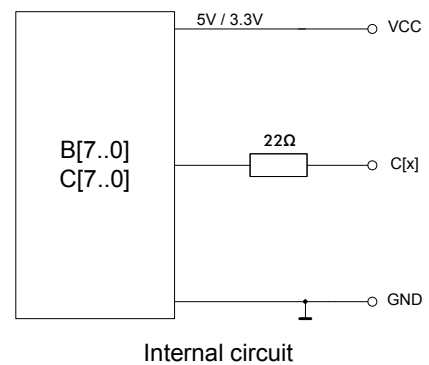

Figure 3: I/O circuit for port B and C

2.4 Switch Input

The I/O port A provides internally 10kΩ pull-up resistors. Therefore, switches can be connected to this port without any additional external circuit.

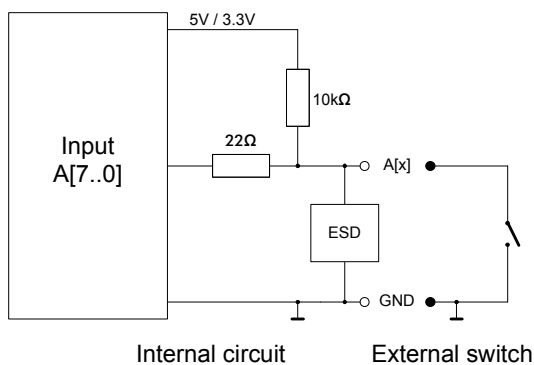

Figure 4: Connecting a switch to port A



2.5 Pin Assignment

In the default configuration, pin 0 to 3 of the I/O block A and the whole block B are configured as input whereas the pin 4 to 7 of the I/O block A and the whole block C are configured as output. This configuration can be changed by using a feature reports.

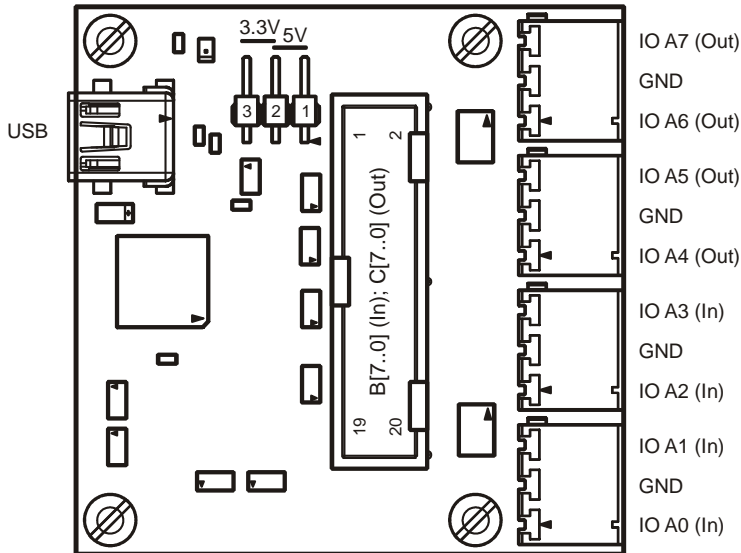

Figure 5: Pin assignment of the Oak IO device (default configuration in parentheses)

The following table contains the pin assignment of the pin header of the I/O block B and C.

| Pin | Name | Default configuration |
|-----|----------|-----------------------|
| 1 | IO B[0] | Input |
| 2 | IO B[1] | Input |
| 3 | IO B[2] | Input |
| 4 | IO B[3] | Input |
| 5 | VCC | |
| 6 | GND | |
| 7 | IO B[4] | Input |
| 8 | IO B[5] | Input |
| 9 | IO B[6] | Input |
| 10 | IO B[7] | Input |
| 11 | IO C[0] | Output |
| 12 | IO C[1] | Output |
| 13 | IO C[2] | Output |
| 14 | IO C[3] | Output |
| 15 | VCC_Stby | |
| 16 | GND | |
| 17 | IO C[4] | Output |
| 18 | IO C[5] | Output |
| 19 | IO C[6] | Output |
| 20 | IO C[7] | Output |



Oak IO Datasheet

VCC and VCC_Stby supply 3.3V or 5V to any external circuit (depending on the jumper setting). In the standby mode, the VCC output is switched off whereas the VCC_Stby output is still powered.

Attention: For being USB compliant, do neither draw more than 150 μ A in standby mode nor more than 450mA totally from VCC and VCC_Stby at any time .

2.6 Jumper Setting

With the jumper, the voltage level mode can be chosen. If the jumper is set between pin 1 and 2, the I/O board is powered with 5V. If the jumper is set between pin 2 and 3, the board runs from a regulated 3.3V supply.

Attention: Please change the jumper position only when the board is disconnected from the host computer and the external circuit.

2.7 Supported I/O Features

Set the digital outputs

Read the digital inputs and outputs

Set I/O direction, output mode and standby behavior of each channel

Set update rate

2.8 USB Interface

Interface: USB 2.0 Full Speed (12Mbits/s)

Connector: Standard USB Mini-B

Device Class: HID

Vendor ID: 0x1B67

Product ID: 0x0010

Update Rate: 1 ms to 65s, user adjustable

Report Rate: 1 ms to 65s, user adjustable

2.9 Operating Temperature Range

Minimum Operating Temperature: -10°C

Maximum Operating Temperature: +85°C



3. Software Specifications

All Oak Devices are implemented as HID devices. Thus driver support is built into all major operating systems.

The digital output data is transmitted through an INTERRUPT OUT report, whereas the reading of the digital input data is transmitted through an INTERRUPT IN report. Therefore real time processing can be guaranteed. The data can be sent and received by the host using regular file write and read operation. Chapter 3.1 and 3.2 describes the contents of this report.

On an independent communication channel, device configuration is done using FEATURE reports that are 32 Bytes in length. Special operating system calls exist to transmit / receive feature reports. Chapter 3.3 shows the structure of a feature report for each supported command.

Please refer also to the document "Programming Guide to the Oak Sensor Family" for more details.

3.1 INTERRUPT OUT Report Contents (Real time data)

The interrupt out report contains the information for switching all the 24 I/O channels.

16 Bit Command for I/O port A[7..0]

16 Bit Command for I/O port B[7..0]

16 Bit Command for I/O port C[7..0]

For each I/O port, a 16 bit setting command has to be sent. Each command has the following structure. The system uses the Little Endian format for the 16 bit number.

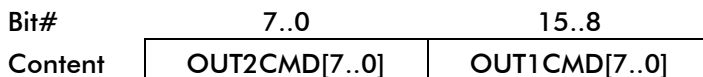

Two bit for each I/O line describe the command (OUT1CMD[x] and OUT2CMD[x]). The following table explains the usage of these commands.

| OUT2CMD[x] | OUT1CMD[x] | Function |
|------------|------------|-------------------------------|
| 0 | 0 | Set pin[x] to 0 |
| 0 | 1 | Set pin[x] to 1 |
| 1 | 0 | Toggle pin[x] |
| 1 | 1 | Hold previous state of pin[x] |

Example

| Port | Content | 16Bit Part | Command | Function |
|------|--------------------|------------|----------------------------|--|
| IO A | OUT1CMD OUT2CMD | LSB MSB | 0b1001'0111 0b0000'0000 | Set port A to 0b10010111 |
| IO B | OUT1CMD OUT2CMD | LSB MSB | 0b1111'1010 0b1111'1111 | Toggle pin 0 and 2 of port B, leave other pins unchanged |
| IO C | OUT1CMD OUT2CMD | LSB MSB | 0b1111'1111 0b1111'1111 | Leave port C unchanged |



3.2 INTERRUPT IN Report Contents (Real time data)

The interrupt in report contains the logic level of all ports.

| | | |
|--------|-------------------|-------------|
| 16 Bit | Frame Number | 10^{-3} s |
| 8 Bit | I/O block A[7..0] | |
| 8 Bit | I/O block B[7..0] | |
| 8 Bit | I/O block C[7..0] | |

3.3 FEATURE Report Commands

3.3.1 Report Mode

| Byte# | 0 | 1 | 2 | 3 | 4 | 5 |
|---------|-----|-----|------|------|------|---------|
| Content | GnS | Tgt | 0x01 | 0x00 | 0x00 | RPTMODE |

GnS: 0 = Set
1 = Get

Tgt 0 = RAM
1 = Flash

RPTMODE: 0 = After Sampling (Factory Default)
1 = After Change
2 = Fixed Rate

3.3.2 LED Mode

| Byte# | 0 | 1 | 2 | 3 | 4 | 5 |
|---------|-----|-----|------|------|------|---------|
| Content | GnS | Tgt | 0x01 | 0x01 | 0x00 | LEDMODE |

GnS: 0 = Set
1 = Get

Tgt 0 = RAM
1 = Flash

LEDMODE: 0 = Off (Factory Default)
1 = On
2 = Blink Slowly
3 = Blink Fast
4 = Blink 4 pulses

3.3.3 Report Rate

Number of milliseconds between two IN reports. This parameter will only be regarded if Report Mode = 2 (fixed rate)

| Byte# | 0 | 1 | 2 | 3 | 4 | 5 | 6 |
|---------|-----|-----|------|------|------|----------------|----------------|
| Content | GnS | Tgt | 0x02 | 0x00 | 0x00 | RptRate LSB | RptRate MSB |

GnS: 0 = Set
1 = Get

Tgt 0 = RAM
1 = Flash

RptRate: Report Rate [ms]



Oak IO Datasheet

3.3.4 Sample Rate

This is the actual sample rate the device is working on. If Report Mode = 0 (After Sampling) this is also the rate at which the device reports values to the host PC.

| Byte# | 0 | 1 | 2 | 3 | 4 | 5 | 6 |
|---------|-----|-----|------|------|------|-----------------|-----------------|
| Content | GnS | Tgt | 0x02 | 0x01 | 0x00 | SampRate LSB | SampRate MSB |

GnS: 0 = Set
1 = Get

Tgt 0 = RAM
1 = Flash

SampRate: Sample Rate [ms]

3.3.5 User Device Name

| Byte# | 0 | 1 | 2 | 3 | 4 | 5-25 |
|---------|-----|-----|------|------|------|------------|
| Content | GnS | Tgt | 0x15 | 0x00 | 0x00 | UsrDevName |

GnS: 0 = Set
1 = Get

Tgt 0 = RAM
1 = Flash

UsrDevName: User defined name for the whole device
Null-terminated string, max. 20+1 characters

3.3.6 User Channel Name

| Byte# | 0 | 1 | 2 | 3 | 4 | 5-25 |
|---------|-----|-----|------|------|------|-----------|
| Content | GnS | Tgt | 0x15 | ChP1 | 0x00 | UsrChName |

GnS: 0 = Set
1 = Get

Tgt 0 = RAM
1 = Flash

ChP1 1 = Channel 0 (Frame Number)
2 = Channel 1 (I/O block A[7..0])
3 = Channel 2 (I/O block B[7..0])
4 = Channel 3 (I/O block C[7..0])

UsrChName: User defined name for the channel
Null-terminated string, max. 20+1 characters

3.3.7 Port A Direction

This configures the pins of the port A as inputs or outputs.

| Byte# | 0 | 1 | 2 | 3 | 4 | 5 |
|---------|-----|-----|------|------|------|------------|
| Content | GnS | Tgt | 0x01 | 0x02 | 0x00 | DIR7..DIR0 |

GnS: 0 = Set
1 = Get

Tgt 0 = RAM
1 = Flash

DIR7..DIR0: 0 = Configures pin as input (Factory Default for Pin 3 to 0)
1 = Configures pin as output (Factory Default for Pin 7 to 4)



Oak IO Datasheet

3.3.8 Port B Direction

This configures the pins of the port B as inputs or outputs.

| Byte# | 0 | 1 | 2 | 3 | 4 | 5 |
|---------|-----|-----|------|------|------|------------|
| Content | GnS | Tgt | 0x01 | 0x03 | 0x00 | DIR7..DIR0 |

GnS: 0 = Set
 1 = Get

Tgt 0 = RAM
 1 = Flash

DIR7..DIR0: 0 = Configures pin as input (Factory Default)
 1 = Configures pin as output

3.3.9 Port C Direction

This configures the pins of the port C as inputs or outputs.

| Byte# | 0 | 1 | 2 | 3 | 4 | 5 |
|---------|-----|-----|------|------|------|------------|
| Content | GnS | Tgt | 0x01 | 0x04 | 0x00 | DIR7..DIR0 |

GnS: 0 = Set
 1 = Get

Tgt 0 = RAM
 1 = Flash

DIR7..DIR0: 0 = Configures pin as input
 1 = Configures pin as output (Factory Default)

3.3.10 Port A Output Mode

This configures the pins of the port A as CMOS compatible push-pull or open drain output.

| Byte# | 0 | 1 | 2 | 3 | 4 | 5 |
|---------|-----|-----|------|------|------|----------|
| Content | GnS | Tgt | 0x01 | 0x05 | 0x00 | OM7..OM0 |

GnS: 0 = Set
 1 = Get

Tgt 0 = RAM
 1 = Flash

OM7..OM0: 0 = Configures pin as CMOS compatible push-pull output (Factory Default)
 1 = Configures pin as open drain output
 This setting is ignored, if the pin is configured as input

3.3.11 Port B Output Mode

This configures the pins of the port B as CMOS compatible push-pull or open drain output.

| Byte# | 0 | 1 | 2 | 3 | 4 | 5 |
|---------|-----|-----|------|------|------|----------|
| Content | GnS | Tgt | 0x01 | 0x06 | 0x00 | OM7..OM0 |

GnS: 0 = Set
 1 = Get

Tgt 0 = RAM
 1 = Flash

OM7..OM0: 0 = Configures pin as CMOS compatible push-pull output (Factory Default)
 1 = Configures pin as open drain output
 This setting is ignored, if the pin is configured as input



Oak IO Datasheet

3.3.12 Port C Output Mode

This configures the pins of the port C as CMOS compatible push-pull or open drain output.

| Byte# | 0 | 1 | 2 | 3 | 4 | 5 |
|---------|-----|-----|------|------|------|----------|
| Content | GnS | Tgt | 0x01 | 0x07 | 0x00 | OM7..OM0 |

GnS: 0 = Set
 1 = Get

Tgt 0 = RAM
 1 = Flash

OM7..OM0: 0 = Configures pin as CMOS compatible push-pull output (Factory Default)
 1 = Configures pin as open drain output
 This setting is ignored, if the pin is configured as input

3.3.13 Standby Configuration

This configures the ports as inputs or outputs.

| Byte# | 0 | 1 | 2 | 3 | 4 | 5 | 6 | 7 | 8 |
|---------|-----|-----|------|------|------|------------------|------------------|------------------|------|
| Content | GnS | Tgt | 0x04 | 0x00 | 0x00 | StbA7.. StbA0 | StbB7.. StbB0 | StbC7.. StbC0 | 0x00 |

GnS: 0 = Set
 1 = Get

Tgt 0 = RAM
 1 = Flash

StbA7..StbA0: 0 = Configures pin as high Z during standby (Factory Default)
 1 = Configures pin to do not change state for standby

StbB7..StbB0: 0 = Configures pin as high Z during standby (Factory Default)
 1 = Configures pin to do not change state for standby

StbC7..StbC0: 0 = Configures pin as high Z during standby (Factory Default)
 1 = Configures pin to do not change state for standby

Attention: For being USB compliant, set all pins to the standby configuration "high Z during standby". Otherwise, depending on the external circuit the board can consume more current in the standby mode than allowed.

3.3.14 Set GPIO

This Feature Report can be used instead of the Interrupt Out Report for setting the GPIO. This feature is only available on modules with firmware version 1.1 or higher.

| Byte# | 0 | 1 | 2 | 3 | 4 | 5 | 6 | 7 | 8 | 9 | 10 |
|---------|-----|------|------|------|------|----|----|----|----|----|----|
| Content | GnS | 0x02 | 0x06 | 0x00 | 0x00 | A1 | A2 | B1 | B2 | C1 | C2 |

GnS: 0 = Set
 1 = Get

A1: OUT1CMD of block A (see section 3.1)

A2: OUT2CMD of block A (see section 3.1)

B1: OUT1CMD of block B (see section 3.1)

B2: OUT2CMD of block B (see section 3.1)

C1: OUT1CMD of block C (see section 3.1)

C2: OUT2CMD of block C (see section 3.1)



4. Technical Specifications

4.1 Current Consumption

| Symbol | Parameter | Conditions | Min | Typ | Max | Unit |
|------------|-------------------|---|-----|-----|-----|---------|
| I_q | Operating current | No load on any I/O | | | 30 | mA |
| I_{Stby} | Standby current | No USB activity, only if pins are configured as "high Z during Standby" | | | 500 | μ A |

4.2 Mechanical Dimensions

The PCB is designed to be mounted using four standard M2 screws. There are no components on the back side of the PCB, but there are through-hole components on top.

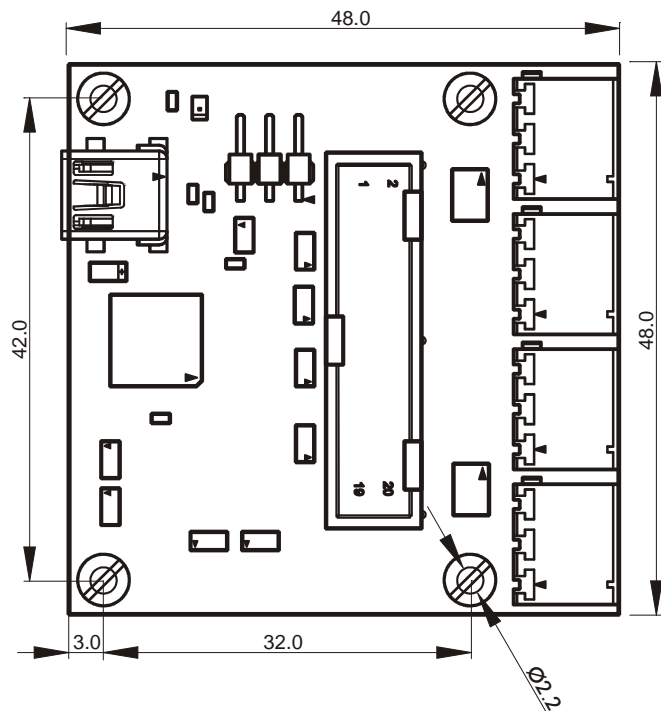

Figure 6: Mechanical dimensions of the Oak IO device

4.3 RoHS Compliance

Unless otherwise stated, all Toradex products comply with the European Union's Directive 2002/95/EC: "Restrictions of Hazardous Substances".



Disclaimer:

Copyright © Toradex AG. All rights reserved. All data is for information purposes only and not guaranteed for legal purposes. Information has been carefully checked and is believed to be accurate; however, no responsibility is assumed for inaccuracies.

Brand and product names are trademarks or registered trademarks of their respective owners. Specifications are subject to change without notice.