

Oak 4-20

4-20mA Current Sensor

including galvanic Isolation and 24V power supply

Datasheet



The picture is slightly different from the original Oak 4-20 device

Revision history

Date	Doc. Rev.	Changes
21-Jun-2011	Rev. 1.5	Disclaimer update
29-Oct-2010	Rev. 1.4	Added Operating Temperature Range
30-Sep-2010	Rev. 1.3	Added USB Vendor ID and Product ID
24-Mar-2010	Rev. 1.2	Corrected Measurement Range (section 2.5)
28-Feb-2008	Rev. 1.1	Add Section Pin Assignment (section 2.3)
03-Sep-2007	Rev. 1.0	Minor Edits (section 1.1)
21-May-2007	Rev. 0.9	Preliminary Release



Contents

1. Introduction	3
1.1 Reference Documents	3
2. Hardware Specifications	4
2.1 24V Power Supply	4
2.2 Current Measurement	4
2.3 Pin Assignment	4
2.4 Equivalent Output Circuit	4
2.5 Measurement Range	4
2.6 Supported Sensor Features	4
2.7 USB Interface	5
2.8 Operating Temperature Range	5
3. Software Specifications	6
3.1 INTERRUPT IN Report Contents (Real time data)	6
3.2 FEATURE Report Commands	6
4. Technical Specifications	8
4.1 Current Consumption	8
4.2 Mechanical Dimensions	8
4.3 RoHS Compliance	8



1. Introduction

The Oak 4-20 is a USB attached precision current sensor. It is designed to be used with off-the-shelf sensors and instruments that offer a standard 4-20mA interface.

The external measuring interface is completely isolated from the USB circuit. In addition, Oak 4-20 provides a galvanically isolated 24V power supply, so the majority of external sensors can be attached without any additional hardware, using only two single wires.

To simplify installation, each Oak 4-20 has a disconnectable interface on the external side. The mating connector has screw terminals to allow for a quick attachment of bare wires.

The Oak 4-20 can be integrated in a custom application very easily. The operating power as well as real time sensor data and uncritical sensor configuration data are all transferred through a simple USB cable. The very low power consumption, including automatic entering into sleep mode, allows using the device not only in fixed installations, but also in mobile applications.

1.1 Reference Documents

Programming Guide to the Oak Sensor Family



2. Hardware Specifications

2.1 24V Power Supply

The 24V power supply is galvanically isolated from the USB circuit. It supplies up to 30 mA on the external terminals.

The power supply has built-in short circuit protection.

2.2 Current Measurement

The current is measured using a 16 bit A to D converter, along with a high precision voltage reference.

2.3 Pin Assignment

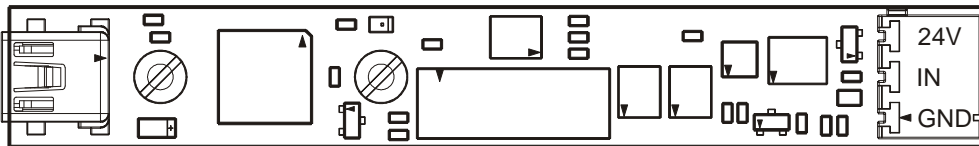

Figure 1: Pin assignment

2.4 Equivalent Output Circuit

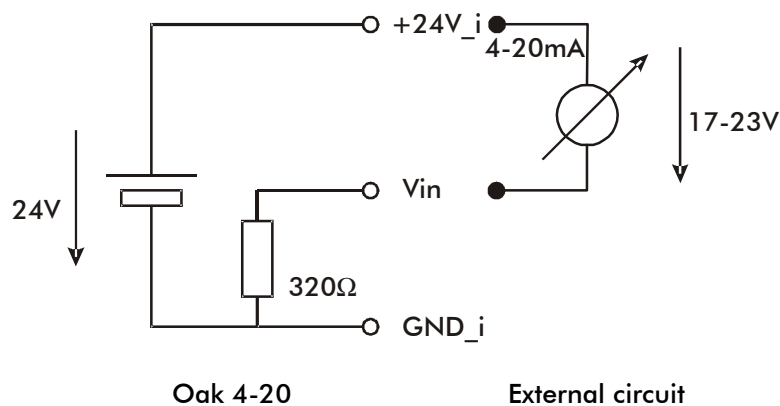

Figure 2: Equivalent output circuit

2.5 Measurement Range

Sensor data are provided in amperes:

Current	Range:	0 – 20.48 mA
	Resolution:	0.0012 mA

2.6 Supported Sensor Features

Read current in amperes

Sample rate adjustable



Oak 4-20 Datasheet

2.7 USB Interface

Interface: USB 2.0 Full Speed (12Mbits/s)

Connector: Standard USB Mini-B

Device Class: HID

Vendor ID: 0x1B67

Product ID: 0x0009

Sampling Rate: 148ms to 65s, user adjustable

Report Rate: 1ms to 65s, user adjustable

2.8 Operating Temperature Range

Minimum Operating Temperature: -10°C

Maximum Operating Temperature: +85°C



3. Software Specifications

All Oak Sensors are implemented as HID devices. Thus driver support is built into all major operating systems.

Captured sensor Data is transmitted through an INTERRUPT IN reports. Therefore real time processing can be guaranteed. This data can be received by the host using regular file read operations. Chapter 3.1 describes the contents of this report.

On an independent communication channel, sensor configuration is done using FEATURE reports that are 32 Bytes in length. Special operating system calls exist to transmit / receive feature reports. Chapter 3.2 shows the structure of a feature report for each supported command.

Please refer also to the document "Programming Guide to the Oak Sensor Family" for more details.

3.1 INTERRUPT IN Report Contents (Real time data)

16 Bit	Frame Number	10^{-3}	s
16 Bit	Current	10^{-6}	A

3.2 FEATURE Report Commands

3.2.1 Report Mode

Byte#	0	1	2	3	4	5
Content	GnS	Tgt	0x01	0x00	0x00	RPTMODE

GnS: 0 = Set
1 = Get

Tgt 0 = RAM
1 = Flash

RPTMODE: 0 = After Sampling (Factory Default)
1 = After Change
2 = Fixed Rate

3.2.2 LED Mode

Byte#	0	1	2	3	4	5
Content	GnS	Tgt	0x01	0x01	0x00	LEDMODE

GnS: 0 = Set
1 = Get

Tgt 0 = RAM
1 = Flash

LEDMODE: 0 = Off (Factory Default)
1 = On
2 = Blink Slowly
3 = Blink Fast
4 = Blink 4 pulses



Oak 4-20 Datasheet

3.2.3 Report Rate

Number of milliseconds between two IN reports. This parameter will only be regarded if Report Mode = 2 (fixed rate)

Byte#	0	1	2	3	4	5	6
Content	GnS	Tgt	0x02	0x00	0x00	RptRate LSB	RptRate MSB

GnS: 0 = Set
 1 = Get

Tgt 0 = RAM
 1 = Flash

RptRate: Report Rate [ms]

3.2.4 Sample Rate

This is the actual sample rate the sensor is working on. If Report Mode = 0 (After Sampling) this is also the rate at which the device reports values to the host PC.

Byte#	0	1	2	3	4	5	6
Content	GnS	Tgt	0x02	0x01	0x00	SampRate LSB	SampRate MSB

GnS: 0 = Set
 1 = Get

Tgt 0 = RAM
 1 = Flash

SampRate: Sample Rate [ms]

3.2.5 User Device Name

Byte#	0	1	2	3	4	5-25
Content	GnS	Tgt	0x15	0x00	0x00	UsrDevName

GnS: 0 = Set
 1 = Get

Tgt 0 = RAM
 1 = Flash

UsrDevName: User defined name for the whole device
 Null-terminated string, max. 20+1 characters

3.2.6 User Channel Name

Byte#	0	1	2	3	4	5-25
Content	GnS	Tgt	0x15	ChP1	0x00	UsrChName

GnS: 0 = Set
 1 = Get

Tgt 0 = RAM
 1 = Flash

ChP1 1 = Channel 0 (Frame Number)
 2 = Channel 1 (Current)

UsrChName: User defined name for the channel
 Null-terminated string, max. 20+1 characters



4. Technical Specifications

4.1 Current Consumption

Symbol	Parameter	Conditions	Min	Typ	Max	Unit
I_a ¹⁾	Operating current				60	mA
I_{Stby}	Standby current	No USB activity			500	μ A

¹⁾ No external load current

4.2 Mechanical Dimensions

The PCB is designed to be mounted using two standard M2 screws. There are no components on the back side of the pcb, but there are through-hole components on top.

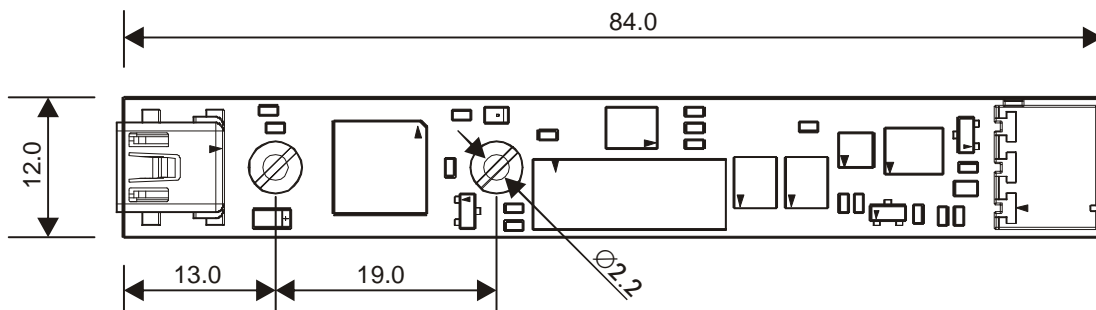

Figure: Mechanical dimensions of the Oak 4-20 sensor

4.3 RoHS Compliance

Unless otherwise stated, all Toradex products comply with the European Union's Directive 2002/95/EC: "Restrictions of Hazardous Substances".



Disclaimer:

Copyright © Toradex AG. All rights reserved. All data is for information purposes only and not guaranteed for legal purposes. Information has been carefully checked and is believed to be accurate; however, no responsibility is assumed for inaccuracies.

Brand and product names are trademarks or registered trademarks of their respective owners.

Specifications are subject to change without notice.